

# Phoenix 2009 School Equipment Show Exhibit Rules & Regulations

**1. Cancellation** - The cancellation or decrease of exhibit space by the Exhibitor must be in writing to Show Management. The fee for cancellation or decrease of exhibit space is based on a percentage of the total rental fee as follows:

10% ➤ On or before August 28, 2009

50% ➤ August 29 – October 2, 2009

100% ➤ On or after October 2, 2009

The above fees will apply whether or not the space is resold. Refunds will be due and payable 30 days after the close of the show. If the Exhibitor does not occupy the exhibit space by 5:00 pm the day prior to the show, then Show Management shall have the right to use such space as it may deem in the show's best interest with no refund of the rental fee or other liability to the Exhibitor.

**2. Exhibitor Registration** - Registration for exhibitors will be in the Convention Center. Badges must be worn to gain admission to the display area. Only authorized exhibitor personnel, registered attendees, and service personnel will be allowed in the exhibit area. Registration fees are set according to the policy of NSSEA outlined in the Exhibitor Registration Form. Use of an exhibitor badge by anyone other than the person named thereon is expressly prohibited. Any violations will result in the automatic removal of the exhibitor badge. Exhibitors witnessing such a violation are urged to report the violation to NSSEA. Since the show is restricted to NSSEA registered attendees and exhibit personnel only, outside guests are not permitted to attend unless registered by NSSEA at published registration fees.

**3. Location of Space** - All exhibits will be located in the Convention Center's designated exhibit areas. No exhibits nor promotion of any type may be located outside the designated exhibit areas or in the parking areas surrounding the Convention Center. Dimensions of all booths shown on the diagram are believed to be accurate but are only warranted to be approximate. NSSEA reserves the right to make such modifications as may be necessary to adjust the floor plan to meet the needs of the NSSEA show and exhibitors. Exhibit space will be allocated to exhibitors on a fair and equitable basis, according to the assignment policies.

**4. Booth Services** - The booth fee includes aisle carpeting and the maintenance thereof, and for linear booths only, standard backgrounds, side railings, and a 7" x 44" I.D. sign containing company name, city, state, and booth number. All other services such as electricity, telephone, furniture, carpeting, etc., must be arranged through the Official Service Supplier of that service. Exhibitor Service Manuals will be available to each exhibiting company approximately 90 days prior to move-in.

**5. Assignment, Subletting of Space** - No exhibitor shall assign, sublet, or share the space allotted without the knowledge and consent of management. No products, parts, accessories, or other goods, souvenirs, catalogs, etc., bearing names or other forms of advertising other than that of the exhibitor may be displayed. No firm or organization not assigned space will be permitted to solicit business within the School Equipment Show facilities. All exhibitors will utilize qualified sales representatives to work in the booth. Only the exhibitor's products may be displayed and/or promoted in booth space contracted for.

**6. Installation** - Installation may begin at 8:00 am on Monday, November 16. All crates are to be removed by 1:00 pm on Tuesday, November 17, with installation complete by 5:00 pm. NSSEA will not allow any move in of exhibits during show hours. Only exhibitors and independent manufacturers representatives will be allowed in the exhibit area prior to the daily exhibit opening as specified in section 11.

**7. Dismantle** - Exhibitors are prohibited from the dismantling and packing of displays prior to the official closing of exhibits at Noon on Friday, November 20, 2009. Any company that dismantles its booth early will lose its priority points for the next year's show.

**8. Local Requirements** - All federal, state, and local laws, codes, fire safety requirements, convention center requirements, and union jurisdictions must be complied with and are the sole responsibility of the Exhibitor. Nothing may be stored behind linear exhibit booths. NSSEA reserves the right to evict any exhibit and impose sanctions on an Exhibitor that fails to or refuses to comply with local requirements. The Exhibitor agrees to obtain adequate insurance to insure against claims resulting from its exhibit.

**9. Care of Building Equipment and Exhibits** - Exhibitors, or their agents, must not injure or deface the walls or floors of the building, the booths, or the equipment of the booths. No nails or tacks can be driven in building walls, floors, or columns, and equipment must be self-supporting. The exhibitor shall indemnify NSSEA for all claims for damage to exhibit space and exhibit premises caused or contributed to by its employees, representatives, and guests. When such damage to the building appears, the exhibitor is liable to the owner of the property damaged.

**10. Exhibit Construction/ Arrangement** - Exhibit backgrounds in all areas except island and peninsula spaces cannot exceed 8' in height, including company names or other advertising, and must be contained in the rear half of the booth area within 10 lineal feet from a cross aisle or adjacent exhibitor. The exhibit height in the front half of the booth measured in from the aisle cannot exceed 4' along the side dividers. In island and peninsula spaces, exhibit height construction is limited to 20' in height. Island spaces may utilize the entire cubic content of the space. Plans for island type exhibits and exhibits not conforming to the above must be approved by the exhibits manager at least two months prior to the opening of the exhibits. Height limitations do not apply to the equipment manufactured in the normal course of business by the exhibitor and displayed in its normal operating position; however, such equipment must remain completely within the confines of the exhibit space. Any part of the exhibit that does not lend itself to an attractive appearance, such as unfinished side or end panels, must be finished at the exhibitor's expense. Management reserves the right to have such finishing done and to bill the exhibitor for charges incurred. Interference with the light and space of other exhibitors is prohibited. Bridging floor surfaces or roof structures across aisles is prohibited.

### **11. Use of Space**

All booths must be open and staffed during the scheduled exhibit hours. The display area will be open to exhibitor personnel one hour before and one hour after the exhibits open and close each day. NSSEA reserves the right to restrict exhibits which, because of noise, methods of operation, materials, or for any reason become objectionable, and also to prohibit or evict any exhibit which, in the opinion of NSSEA, may detract from the general character of the show as a whole. All demonstrations or other promotional activities must be confined within the limits of the exhibit booth. Demonstrations or activities that cause annoyance to neighboring exhibitors such as flashing lights or noise, or result in obstruction of aisles or prevent ready access to a nearby exhibitor's booth will not be allowed. Exhibitors must take every reasonable precaution to minimize the noise of demonstrations or of operating sound devices, sound film, cutaway models, etc. Exhibitors shall distribute printed matter, souvenirs, or other articles only within the confines of the exhibit space. Throwing of souvenirs, loud shouting, and making of any unnecessary noise to attract attention will not be permitted. Musicians and singers are prohibited. Models or other entertainers will not be permitted to wear attire other than that which conforms to normal business or daytime social standard. NSSEA reserves the right of approval of said models and the attire of other booth personnel. If inflated, balloons must be displayed within limitations of the Regulations. Inflated balloons must be inflated only with air or heavier than air gas. Helium is not permitted. An Exhibitor shall not display products or offer products in its literature or other media displayed at the show that have been declared by a U.S. governmental authority or court to infringe on another exhibitor's U.S. intellectual property rights (patent, trademark, trade dress or copyright). In its sole discretion NSSEA may impose appropriate sanctions on an Exhibitor for violation of this provision, including but not limited to closing the Exhibitor's booth. Each Exhibitor warrants that it owns the rights to use all U.S. intellectual property to be used by the Exhibitor for promotion and exhibition at the show. Exhibitors shall be responsible for securing all necessary licenses or consents for any use of copyrighted works (including music licenses) or other intellectual property in connection with their exhibit and hospitality events at the show.

**12. Photograph and Video** - Cameras (including cell phone cameras) are allowed on the show floor. However, attendees/show participants shall not photograph or record the exhibit or products of any Exhibitor unless authorized by the Exhibitor. Violation may result in the confiscation of the attendee's camera or other media and/or removal from the exhibit hall.

**13. Security** - NSSEA will provide necessary perimeter security guards at all times during the show, move in and move out. However, exhibitors are solely responsible for the care, custody, and control of their own exhibit material. It is suggested that exhibitors carry insurance for covering loss or damage to their exhibit material.

**14. Liability** - Neither NSSEA, Exposition Management, Inc., the Convention Center, nor their representatives will be responsible for any injury, loss, or damage that may occur to the exhibitor or to the exhibitor's employees or property from any cause whatsoever. The exhibitor, on signing this contract, expressly releases the forgoing named association, corporations, and individuals from all claims for such loss, damage, or injury.

**15. Food/Beverage Dispensing** - Exhibitors may not dispense food and/or beverages without the written permission from the exclusive provider of this service at the Convention Center. The serving of alcoholic beverages in the exhibit hall is not allowed.

**16. Cash Sales** - No cash sales are permitted during the show.

**17. Successors in Interest** - This agreement shall bind the respective parties and their successors in interest.

**18. Non-Waiver** - No waiver of any breach of this contract shall be held to be a waiver of any other or subsequent breach.

**19. Force Majeure** - In case of cancellation of the exhibition or unavailability of the exhibit space for the specified uses due to war, governmental action or order, act of God, fire, strike, labor disputes, or any other causes beyond the Association's control, the agreement shall terminate, and the exhibitor shall be entitled to the return of the exhibit space rental fee, less the pro rata share allocable to the exhibit space of the expenses incurred by NSSEA in connection with the exhibition. In case of cancellation by NSSEA for any other reason, or a change in the place or date of the exhibition that is unsatisfactory to the exhibitor, the exhibitor shall be entitled to return of sums paid for the space. Refund of the rental fees shall be the exclusive remedy of the exhibitor against NSSEA in the event the exhibition is cancelled or rescheduled or the exhibit space is unavailable for use.

**20. Governing Law** - This agreement shall in all respects be governed by the laws of the State of IL.

**21. Outside Events** - Exhibitors are prohibited from holding events in conflict with official NSSEA events and during exhibit hours. Companies that schedule outside events for dealers during NSSEA events will lose their priority points for next year's show.

**22. Agreement to Comply** - This application for booth space at the School Equipment Show will become a contract upon mutual acceptance, and is based upon these Exhibit Space Rules and Regulations, the plan of exhibits, the booth assignment policy, and general information in the NSSEA Exhibitor Service Manual. Please read the Exhibit Space Regulations carefully before signing. All exhibiting companies agree that their employees will abide by these rules and regulations and any additions and/or amendments that NSSEA shall put into effect, and they shall remain as exhibitors from day to day, solely on their strict compliance with these rules. They have been formulated in the best interest and for the protection of the exhibitors as well as NSSEA and its representatives. In any interpretations of the rules, the judgment of NSSEA shall be final, and any matters not covered are subject to the decision of NSSEA. Acceptance as an exhibitor at the School Equipment Show in no way means or implies endorsement of the exhibitors' products and/or services by NSSEA.

**23. Children** - For the safety of our future customers and to protect the business environment of the tradeshow, children under the age of 16, carriages, and strollers are not permitted in the exhibit hall and/or workshops at any time. Infants are permitted with a signed waiver, but must be carried at all times.

**24. Registration** - Registration at the School Equipment Show is a license granted by NSSEA and may be revoked at any time. For exhibitor badges, exhibitors may only register their company personnel under their company name.

# **The School Equipment Show**

**NOVEMBER 18 - 20, 2009 - - PHOENIX CONVENTION CENTER**

## **DISPLAY RULES AND REGULATIONS**

Display Rules and Regulations have been with us since trade shows first began. Most individuals recognize the need for some limitations but have never taken the time to determine the intent of each rule, when they were written, what they are expected to accomplish and, most important, how an exhibitor can use them effectively.

The tenet on which all management is based can be summed up as follows:

All exhibitors are equal, regardless of size, and should be given an equal opportunity, within reason, to present their product to the audience in the most effective manner.

Show management must establish rules or guidelines to make this possible while allowing the greatest flexibility within each exhibit. Remember you are our customers. We want you to be successful.

The exhibitor's responsibility can be summed up far more simply:

"Be a good neighbor."

With these thoughts in mind, please review the rules and regulations outlined on the following pages. Each section begins with the actual rule or guideline and is followed by the intent, which is of major importance. By recognizing the intent, you can be reasonably sure you will always be "a good neighbor."

# The School Equipment Show

**IMPORTANT:** Space dimensions shown on floorplan are from center line of booth equipment, such as side rails and/or back drape. Exhibit structures must be constructed to allow sufficient tolerance on each side for this equipment and for utility service at rear of booth.

## Standard Back to Back (Linear) and Perimeter Booths:

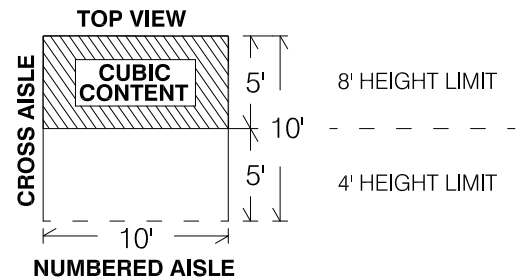
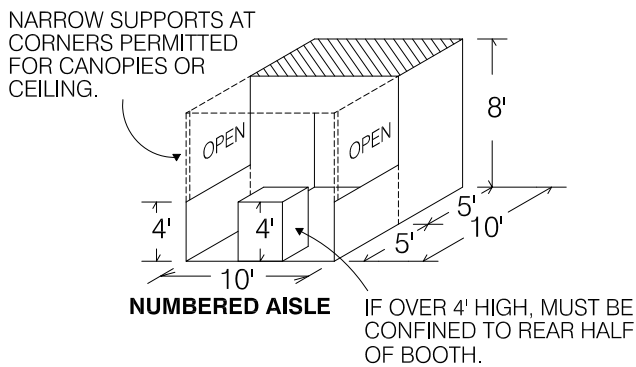

**DEFINITION:**

One or more 10' x 10' booths in a straight line.

**BOOTH DESIGN:**

Standard linear booths may not exceed allowable 8' height shown. Perimeter linear wall booths may not exceed allowable 12' height. All display fixtures over 4' in height and within 10 lineal feet of an adjoining booth or cross-aisle must be confined to the back half of the booth.

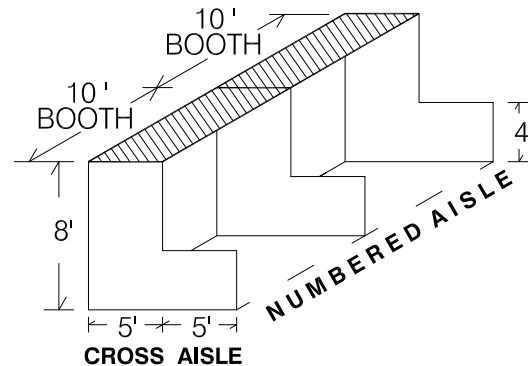

Exhibitors using ceilings over their exhibit may use a single narrow vertical support in the corners of their space.

Vertical supports that are strictly decorative will not be permitted.

**INTENT:**

Each exhibitor is entitled to a reasonable sight line from the aisle, regardless of the exhibit size.

Exhibitors with 30 lineal feet or more of space should be able to use as much of the total floor space as possible if they do not interfere with the rights of others. The limitation on display fixtures over 4' and within 10 lineal feet of a neighboring exhibit or cross-aisle is intended to accomplish both of these aims.

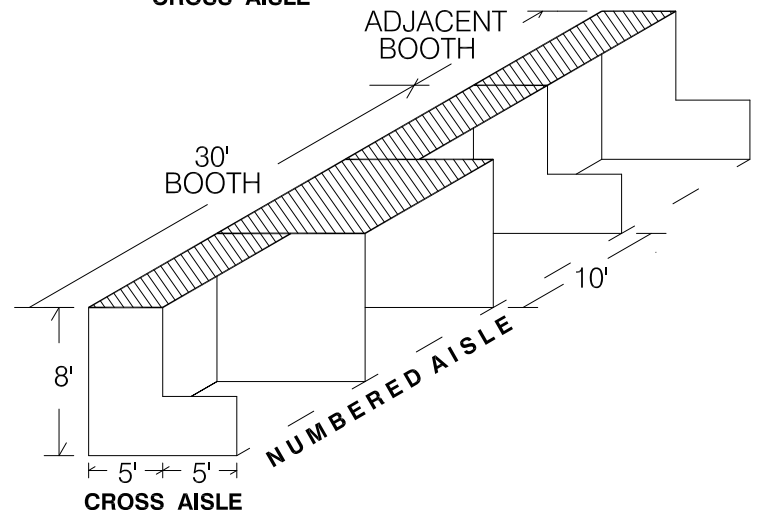

## Island Booths:

### DEFINITION:

An island booth is 20' x 20' or larger and exposed to aisles on all four sides.

### HEIGHT:

Exhibit fixtures, components and identification signs will be permitted to a maximum height of 20' (6.1m), provided written approval is received from Show Management at least 60 days prior to show.

### INTENT:

When an island booth exceeds 8' (2.5m), it does not interfere with other exhibitors because it obviously does not back up against another exhibitor's back wall. The extra height is often required in an island booth exhibit to permit the open walk-through approach normally used in this type of location. The 20' (6.1m) maximum height limitation has been set to avoid undue competition between exhibitors to see who can go the highest or be seen the farthest away with each negating the other's efforts. Also, the 20' (6.1m) high exhibit will fit into most exposition centers, thus permitting each exhibitor to get the maximum use of the exhibit.

### DEPTH:

Because an island booth is automatically separated by the width of an aisle from all neighboring exhibits, full use of the floor plan is permitted.

### STRUCTURAL INTEGRITY:

All multi-story exhibits, regardless of whether people will occupy the upper area or not, and all exhibits and components exceeding 12'0" (3.66m) in height must have drawings available for inspection by Show Management, the installation and dismantling contractor, and the exhibitor and governmental authority during the time the exhibit is being erected, exhibited, and dismantled at the show site. They must include a signature or stamp of a reviewing structural engineer indicating that the structure design is properly engineered for its proposed use, and a signature of an authorized official of the exhibit building company indicating that the structure is built in compliance with the details and specifications set forth on the drawings. Signs must also be posted indicating the maximum number of people the structure will accommodate.

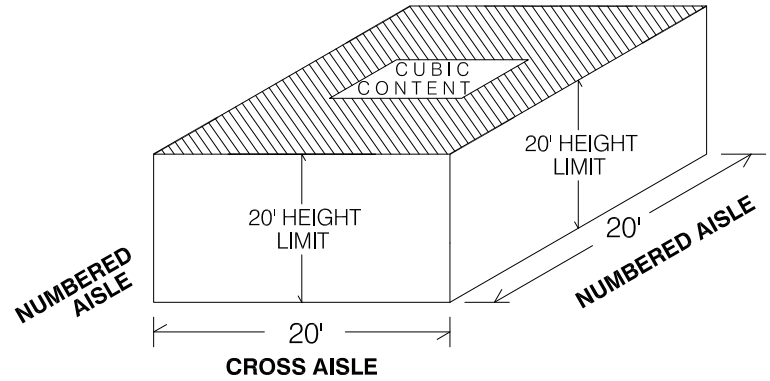

### TOP VIEW

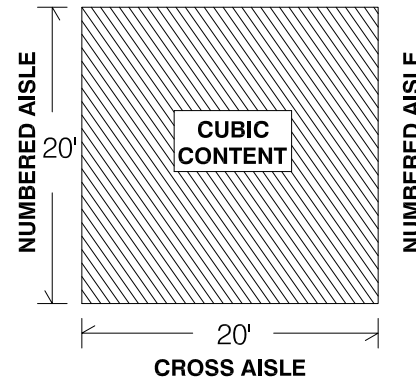

### PERIMETER OPENINGS:

Large islands with long high walls can create a "tunnel-like" effect. Exhibitors may be required to install a minimum 6ft (1.83m) opening every 30ft (9.14m)

### INTENT:

Exhibitors in the vicinity of island exhibits are entitled to the same reasonable safety precautions they would expect if they were adjacent to a standard booth.

### IMPORTANT:

Exhibitors are cautioned when installing a display with a ceiling or second level to check with the local fire department to insure that their display meets with the necessary fire safety precautions involving smoke alarms, fire extinguishers, sprinkler systems, etc.

# DEMONSTRATIONS OR ENTERTAINMENT

## REGULATION:

Do not place your demonstration areas on the aisle line of your exhibit if you expect many people to congregate at one time. Leave space within your own exhibit area to absorb the majority of the crowd. Should spectators interfere with the normal traffic flow in the aisle or overflow into the exhibits of your neighbors on each side or across the aisle, Show Management will have no alternative but to request that you limit or eliminate the presentation.

## SOUND:

Management encourages exhibitors to enhance the show for their company and their buyers by in-booth product demonstrations, videos, etc. However, Show Management feels that Sound Control Regulations are in the best interest of all exhibitors and buyers.

1. Exhibitors shall not be permitted to operate audio amplification systems at levels that are greater than **6db Sound Pressure Level (SPL)** above the ambient noise level measure at any neighboring area.
2. Sound Pressure Levels will be measured with a calibrated Sound Level Meter (calibrated to ANSI Standards) set for C-weighting response and "slow" meter characteristics. Measurements may be made in any nearby or adjacent exhibit area at any height or incidence angle relative to the booth using the amplification system.

## INTENT:

The aisles are the property of all exhibitors, and therefore, each exhibitor has the responsibility to assure proper flow of traffic through the entire show. When large crowds gather to watch a demonstration or entertainment and interfere with the flow of traffic down aisles or create excessive crowds in neighboring booths, this is an infringement on the other exhibitors' rights. Aisles must not be obstructed at any time.

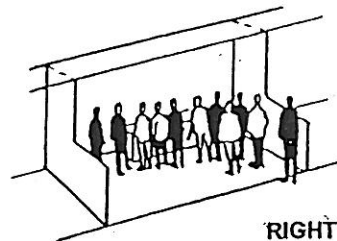

**IMPORTANT:** Space dimensions shown on floorplan are from center line of booth equipment, such as side rails and/or back drape. Exhibit structures must be constructed to allow sufficient tolerance on each side for this equipment and for utility service at rear of booth.